

**SCHEDULE OF LAND :-**

MOUZA	: SILIGURI DAKHSIN-2
PARGANA	: BAIKUNTHAPUR
J.L. NO.	: 93
KHATIAN NO.	: 2570 (R.S.), 7024 (L.R.)
PLOT NO.	: 11828/13070 (R.S.), 619 (L.R.)
SHEET NO.	: 20 (R.S.)
WARD NO.	: 30 (S.M.C.)
HOLDING NO.	: VL/100/G/4
P.S.	: SILIGURI
DISTRICT	: DARJEELING

LAND AREA (AS PER DEED)	- 518.39 SQM.
LAND AREA (AS PER SITE)	- 518.39 SQM.
L.U.C.C. MEMO NO.	- 12224/SJDA Dated 19.12.2023

**Area Statement Summary**

Rule No	Parameter	Minimum Required	Maximum Permissible	Provided	Result
303	Building Height	N/A	20.50	15.00	Satisfied
401	Area	N/A	2.00	1.00	Satisfied
401/1a/1b	Ground Coverage (in Percentage)	N/A	30	47.11	Satisfied
	Plot Area	N/A	N/A	518.39	N/A
	Minimum Width of Plot	N/A	N/A	17.00	N/A
	Total Building Area	N/A	N/A	1207.52	N/A
	Plot Area for FSI	N/A	N/A	1008.25	Satisfied
	Covered Area	N/A	N/A	244.23	Satisfied

Proposed Height of the Building No. of Stories

Block Name	Number of Floors	Height of the Building
Single Building	Partly 4 Floors	14.50

As per Web Input

Comparison of Total Builtup Area	Result
As per Drawing	Satisfied
244.23	244.23

As per Web Input

Comparison of Building Category	Result
As per Drawing	Satisfied
Residential	RESIDENTIAL BUILDING

**Block Name**

Floor Name	Total Area	Exclusion Area	Balance Occupancy Area (A1/A2/A3)	Covered Parking	Exemption for Covered Parking	Floor Area (Net PAR)
FLOOR01	248.88	11.07	237.81	12.78	12.78	244.23
FLOOR02	248.88	11.07	237.81	12.78	12.78	244.23
FLOOR03	248.88	11.07	237.81	12.78	12.78	244.23
FLOOR04	248.88	11.07	237.81	12.78	12.78	244.23
FLOOR PARKING	248.88	11.07	237.81	12.78	12.78	8.54
FLOOR TERRACE	248.88	11.07	237.81	12.78	12.78	0.00
Total	1344.40	66.36	1278.04	104.04	104.04	893.44

Area to be Excluded and Exemption from Floor Area if provided in the Drawing

List of Exemption: Lift, Stair, Common Ventilation Shaft

List of Exemption: Staircase, Staircase Landing, Lift Lobby, Service Equipments

**Block Name**

Floor Name	Occupancy	Occupancy Area (Gross)	Occupancy Area (Net)
FLOOR01	RESIDENTIAL	248.88	244.23
FLOOR02	RESIDENTIAL	248.88	244.23
FLOOR03	RESIDENTIAL	248.88	244.23
FLOOR04	RESIDENTIAL	248.88	244.23
Total		995.52	893.44

**Building Name**

Floor Name	Tenements Reference	Single / Duplex	Tenements Area
FLOOR01	S.S.C.	Single	86.10
FLOOR02	PLAT B	Single	86.02
FLOOR03	PLAT C	Single	86.10
FLOOR04	PLAT D	Single	86.02
Total			344.24

Total number of Tenements: 16

**Parking Details (Calculation)**

Rule No	Parameter	Area for Calculating Parking	Cars Required	Truck/Bus required
42 (B)(1)	Tenements	344.24	17	N/A
	Tenements Above 60 Sq.M	17	842.32	8
Total			842.32	8

**Parking (Garage) Details**

Rule No	Parameter	Minimum Required	Maximum Permissible	Provided	Result
52A(1)(a)	Parking Near Room Height (Car)	2.2	N/A	2.85	Satisfied
52B(1)	Car Parking Space	6.0m	N/A	6.0m	Satisfied
52B(1)	Covered Parking Space	N/A	N/A	8	N/A
52B(1)	Openair Parking Space	N/A	N/A	Not Provided	N/A
52B(1)	Ratio of Garage	0.15	N/A	Not Provided	N/A

**Occupancy Details**

Block Name	Floor Name	Occupancy	Occupancy Area (Gross)	Occupancy Area (Net)
Single Building	FLOOR01	RESIDENTIAL	248.88	244.23
	FLOOR02	RESIDENTIAL	248.88	244.23
	FLOOR03	RESIDENTIAL	248.88	244.23
	FLOOR04	RESIDENTIAL	248.88	244.23
Total			995.52	893.44

**Tenements Details**

Building Name	Floor Name	Tenements Reference	Single / Duplex	Tenements Area
Single Building	FLOOR01	S.S.C.	Single	86.10
	FLOOR02	PLAT B	Single	86.02
	FLOOR03	PLAT C	Single	86.10
	FLOOR04	PLAT D	Single	86.02
Total				344.24

**Signature of Owner**

Signature of L.B.S.

I DO HEREBY DECLARE THAT THE BUILDING PROPOSED FOR CONSTRUCTION SHALL BE SUPERVISED BY THE B. A. / I. B. S. SIGNING THE BUILDING PLAN APPLICATION OR IN HIS ABSENCE BY ANY OTHER B. A. / I. B. S. OF THE APPROPRIATE CATEGORY AND AS APPROVED BY THE AUTHORITY.

**SIGNATURE OF OWNER**

I DO HEREBY CERTIFY THAT PLANS, ELEVATIONS AND SECTIONS AND OTHER STRUCTURAL DETAILS OF THE PROPOSED BUILDING ON PLOT NO. 11828/13070 (R.S.), 619 (L.R.), STREET - SURYASEN COLLEGE STREET, WARD NO-30, UNDER JURISDICTION OF SILIGURI M.C. HAVE BEEN PREPARED IN CONFORMITY WITH ALL RELEVANT PROVISIONS UNDER THE WEST BENGAL MUNICIPAL BUILDING RULES, 2007. THIS ALSO TO CERTIFY THAT ALL RELEVANT NO OBJECTION CERTIFICATES FROM THE RESPECTIVE AUTHORITIES SUCH AS, FIRE AND EMERGENCY SERVICES DEPARTMENT, AIRPORT AUTHORITY, POLLUTION CONTROL BOARD, TELECOMMUNICATION DEPARTMENT ETC. AS APPLICABLE IN THIS REGARD ARE ALSO ENCLOSED WITH THE APPLICATION FOR SEEKING APPROVAL OF THE PLAN TO CONSTRUCT OF THE BUILDING ON THE SAID PLOT.

**SIGNATURE OF STRUCTURAL ENGINEER**

I DO HEREBY CERTIFY THAT THE FOUNDATION AND SUPERSTRUCTURE OF THE BUILDING PROPOSED FOR CONSTRUCTION ON PLOT NO. 11828/13070 (R.S.), 619 (L.R.), STREET - SURYASEN COLLEGE STREET, WARD NO-30, UNDER JURISDICTION OF SILIGURI M.C. HAVE BEEN PERSONALLY INSPECTED AND SO DESIGNED BY ME/US WILL MAKE SUCH FOUNDATION AND SUPERSTRUCTURE SAFE IN ALL RESPECTS INCLUDING THE CONSIDERATION OF BEARING CAPACITY AND SETTLEMENT OF SOIL AND OTHER CONDITIONS, IF ANY, CONFORMING TO THE STIPULATION OF ALL RELEVANT CODE OF PRACTICE AND NATIONAL BUILDING CODE.

**SIGNATURE OF L.B.S.**

**SIGNATURE OF STRUCTURAL ENGINEER**

**SIGNATURE OF STRUCTURAL ENGINEER**

**SIGNATURE OF STRUCTURAL ENGINEER**

**SIGNATURE OF STRUCTURAL ENGINEER**

**SIGNATURE OF STRUCTURAL ENGINEER**

**SIGNATURE OF STRUCTURAL ENGINEER**

**SIGNATURE OF STRUCTURAL ENGINEER**



**SHEET**

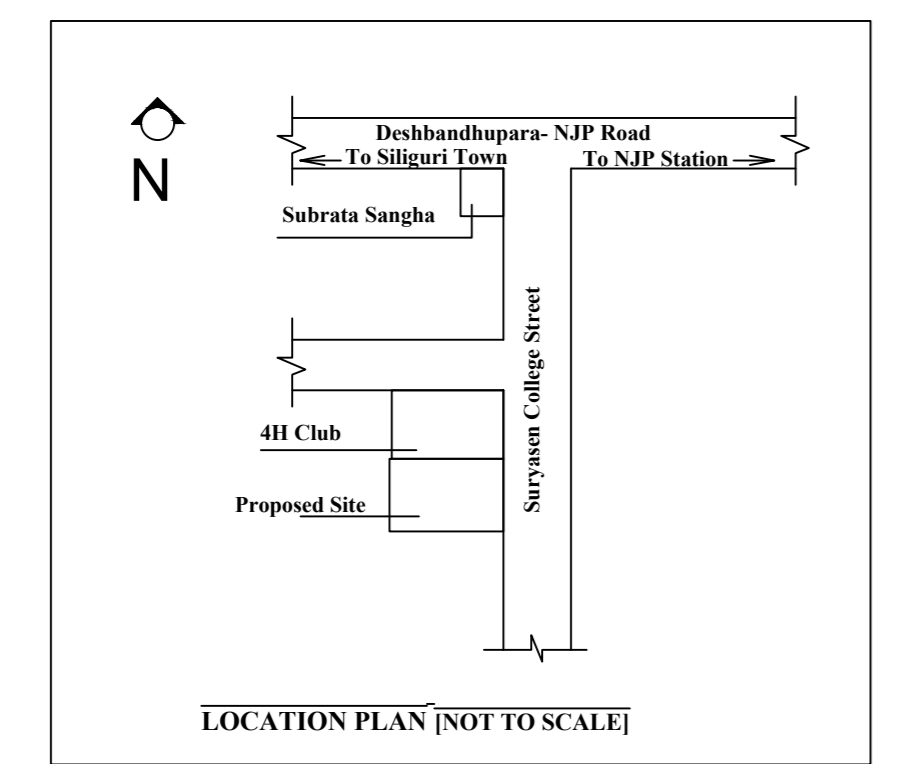
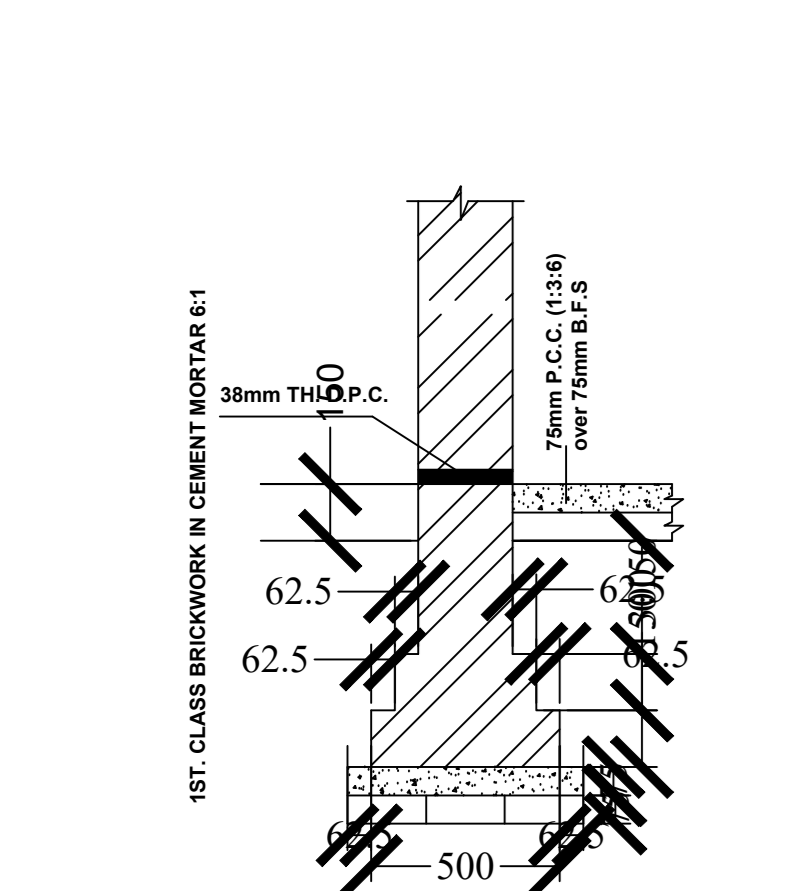
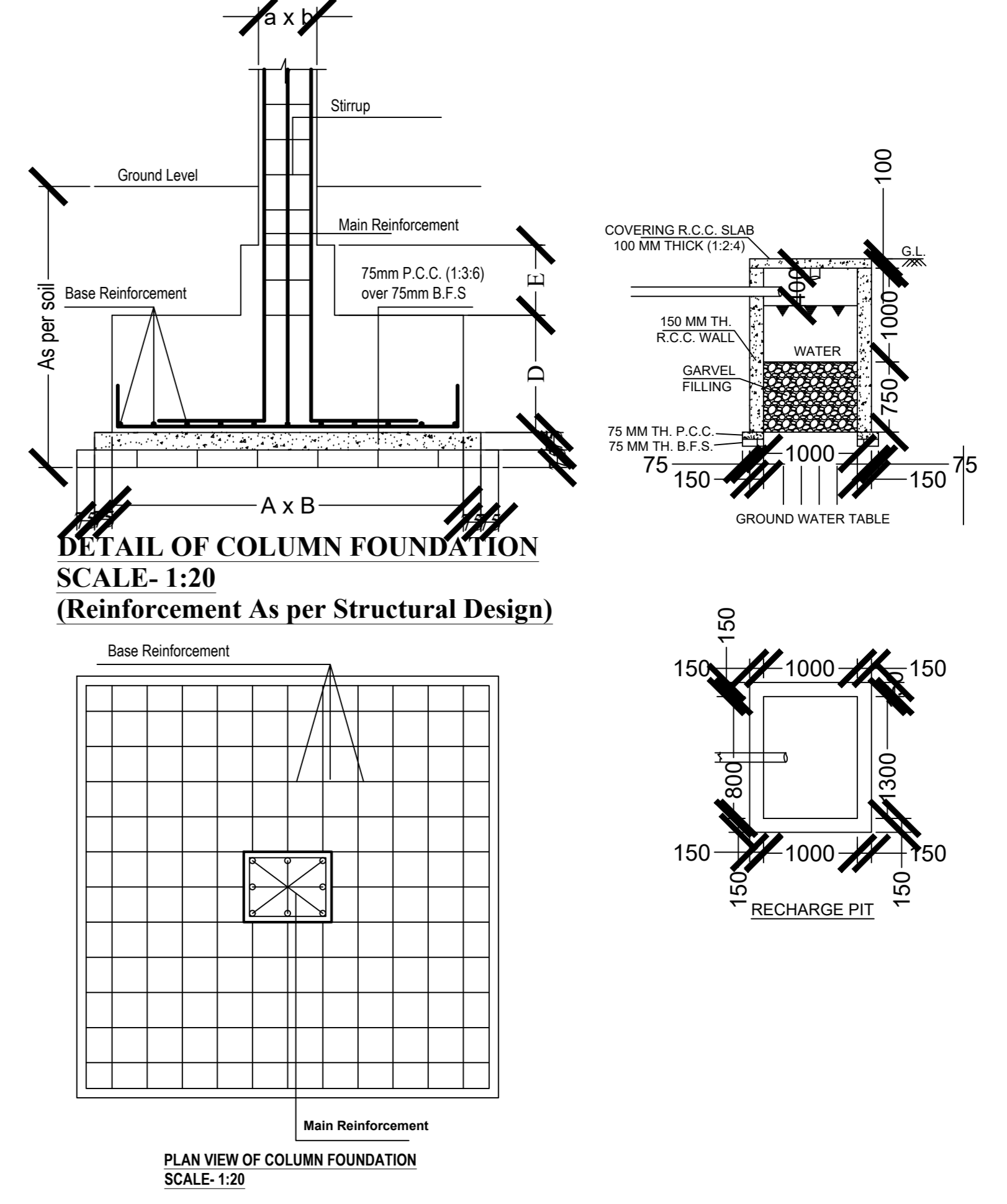
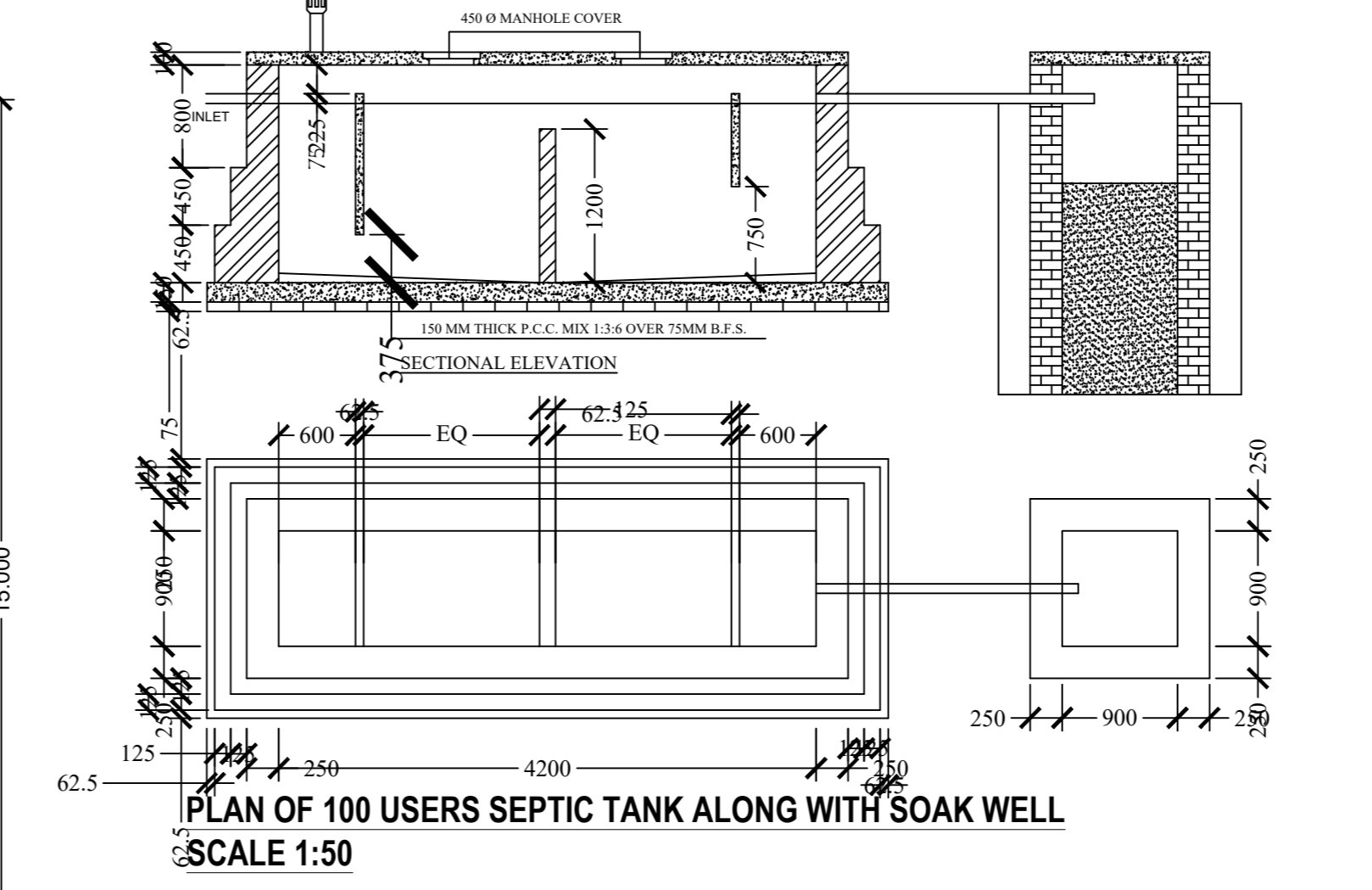
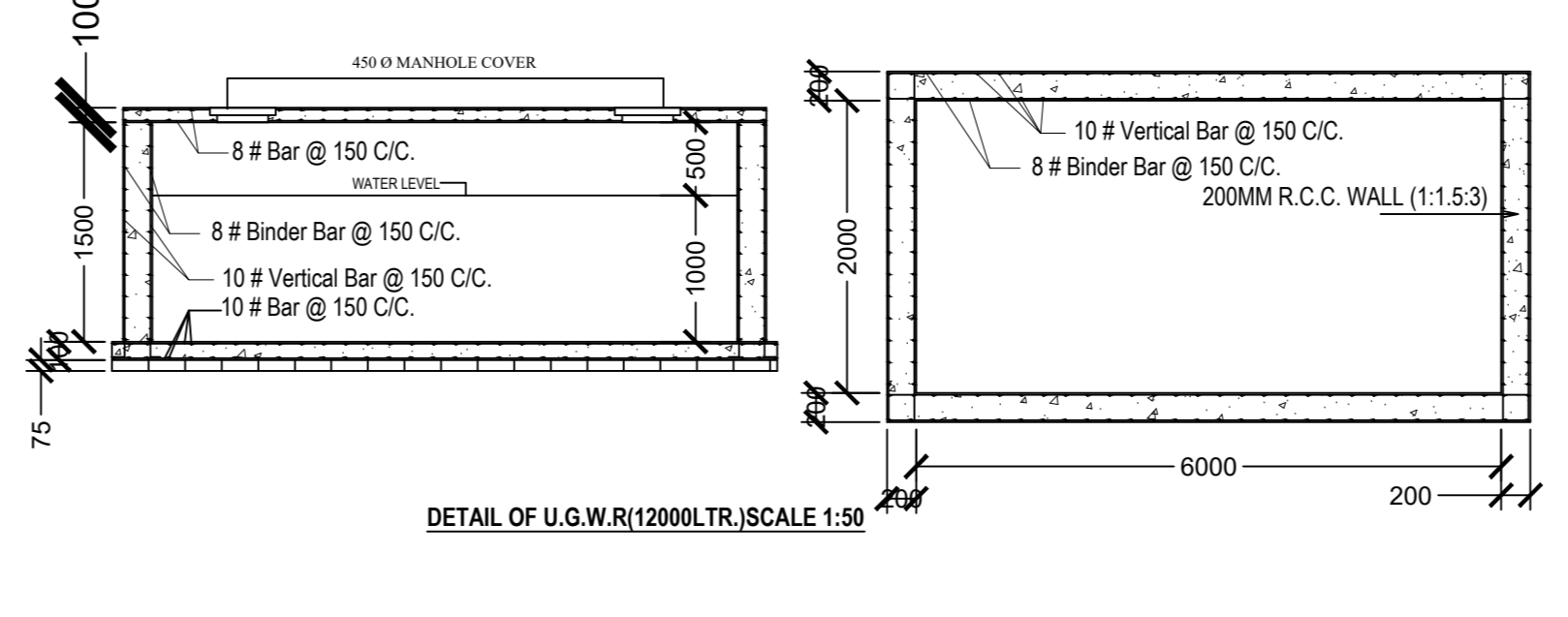
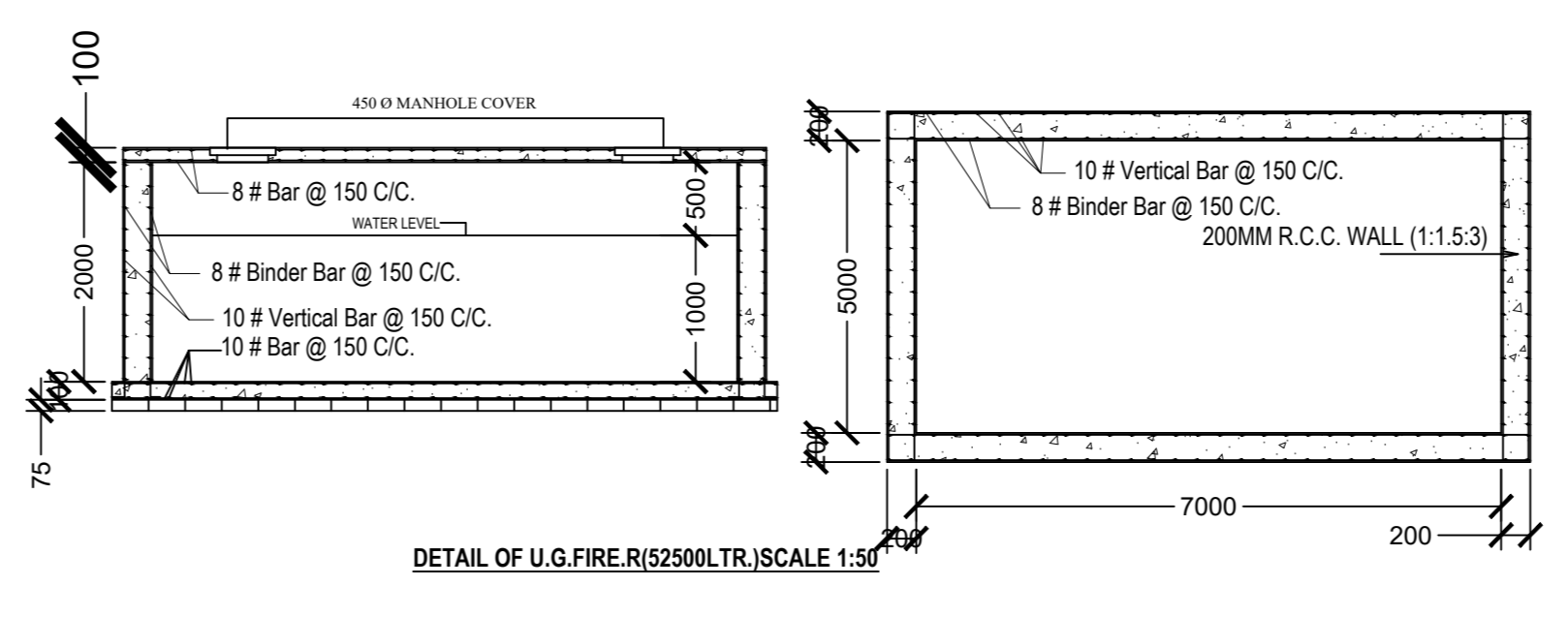

**Schedule of Opening:-**

W	- Window	- 1200 x 1200
W1	- Window	- 1500 x 1350
V	- Ventilator	- 600 x 900
D	- Door	- 900 x 2100
D1	- Door	- 750 x 2100
D2	- Door	- 1050 x 2100

**SPECIFICATION OF MATERIALS :-**

- SOLLING - 75mm THK. FIRST CLASS PICKED BRICKS.
- R.C.C. - M-20 (1:1.5:3)
- P.C.C. - 1:3:6 CEMENT CONG.
- STEEL - Fe-415 TOR STEEL.
- BROCK WORKS - 125 THK. 8:250 THK. 1:4 MORTAR.
- PLASTER - 12mm. IN WALL & 6mm. IN CEILING WITH 1:4 MORTAR.
- FLOOR - ORDINARY FLOORING.
- D.W. FRAME - SAL WOOD WITH 65X125 mm. SECTION.
- D.W. SHUTTER - TEAK PANSALU WOOD PANEL LEAF 38 mm. THK.
- PAINTING - INTERIOR WALL IN LINE FINISHING WITH PLASTIC PAINTS AND OUT SIDE WALL CEMENT PAINTS DW PAINTED WITH SYNTHETIC ENAMEL.
- ON W.TANK - BITEX. 1000 LTR. CAPACITY X 1 NO.

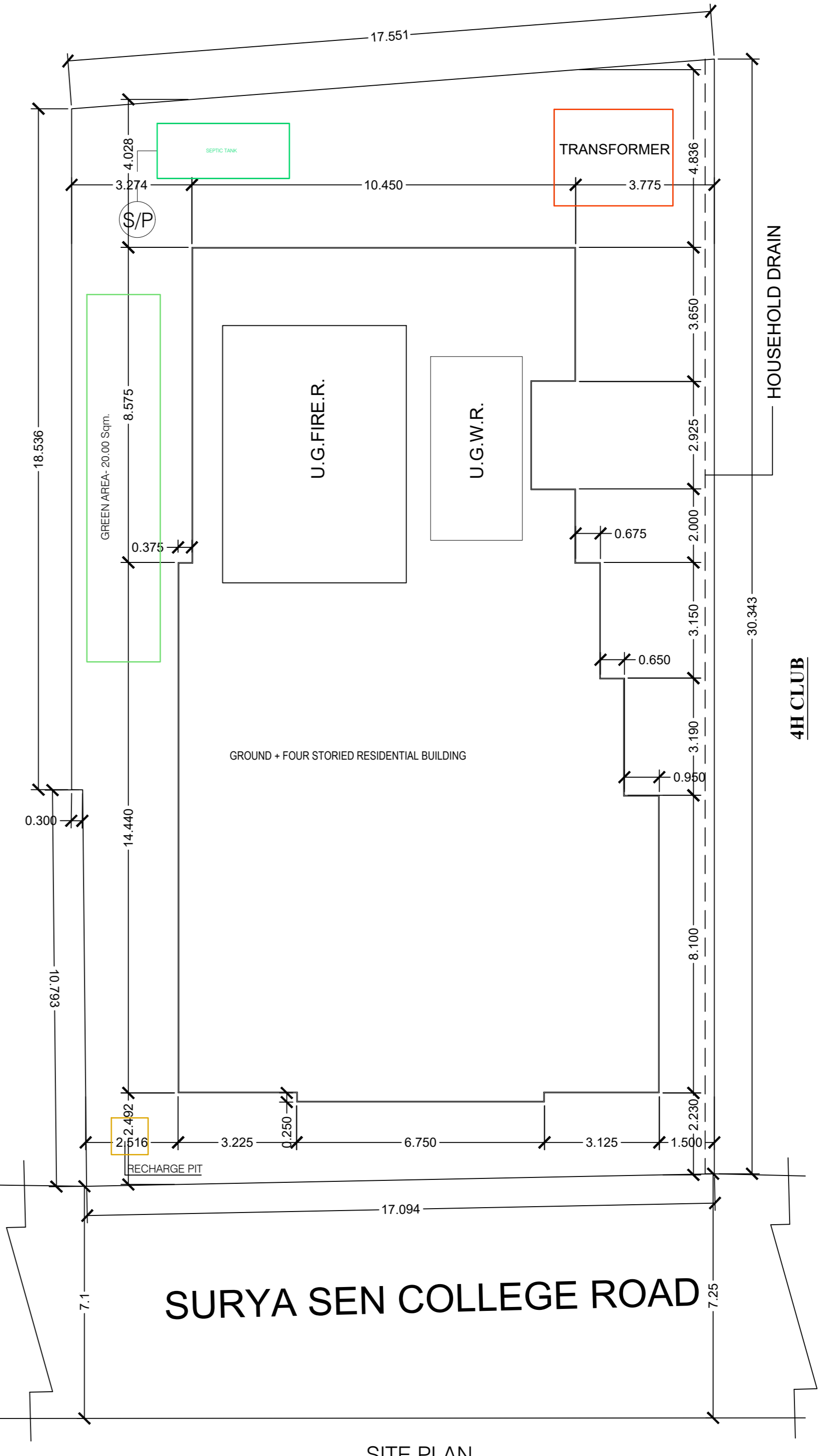
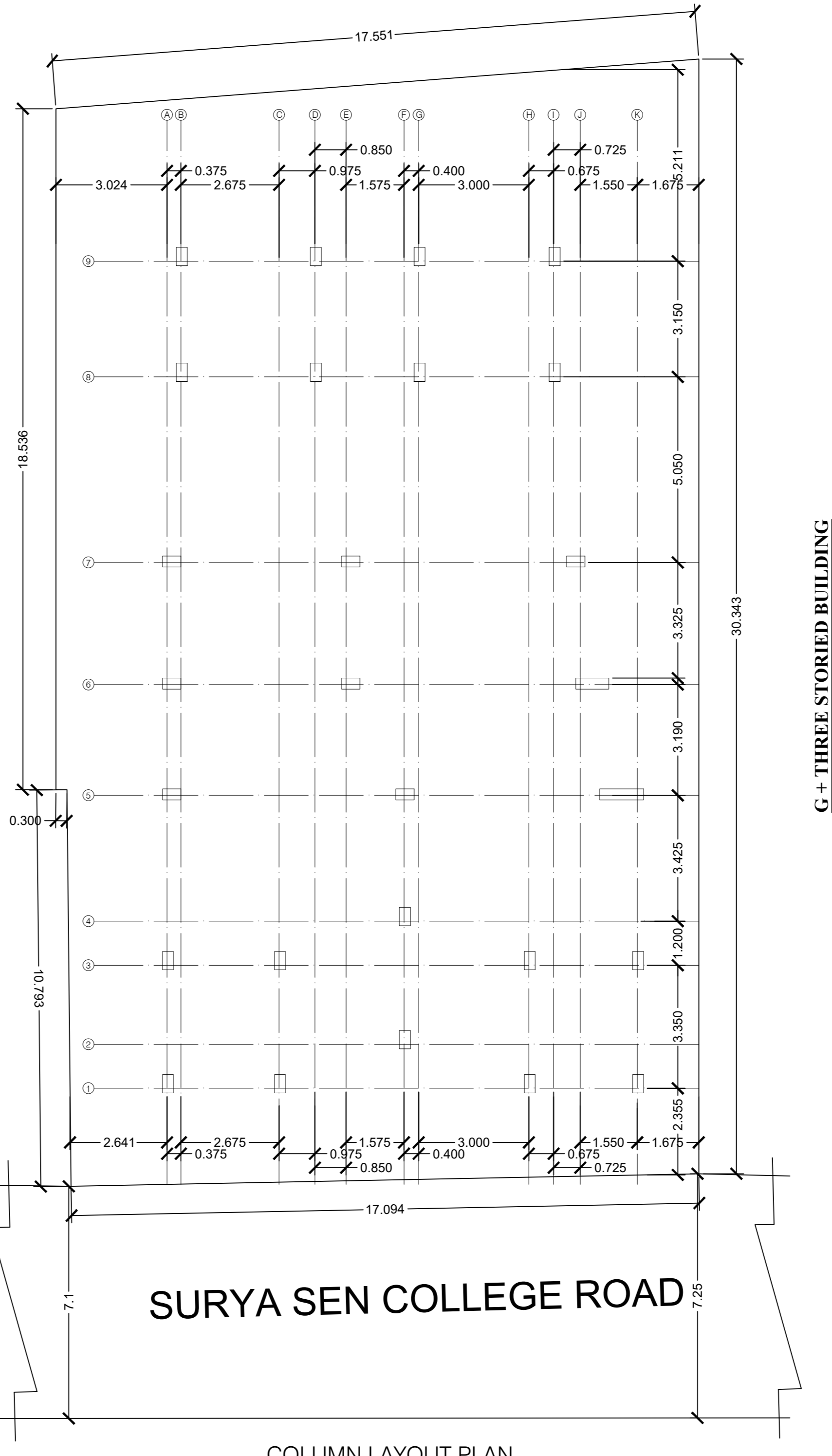
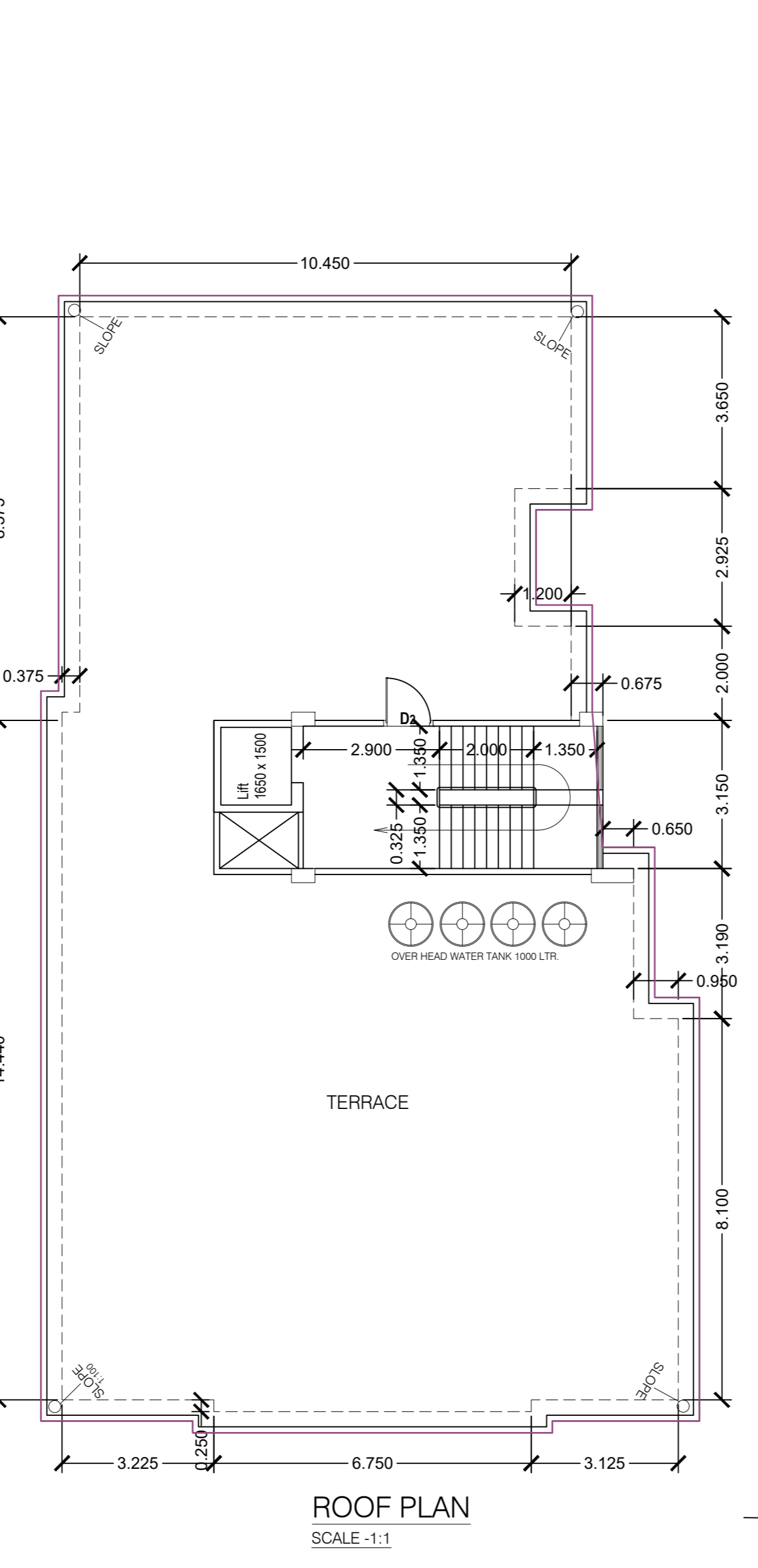
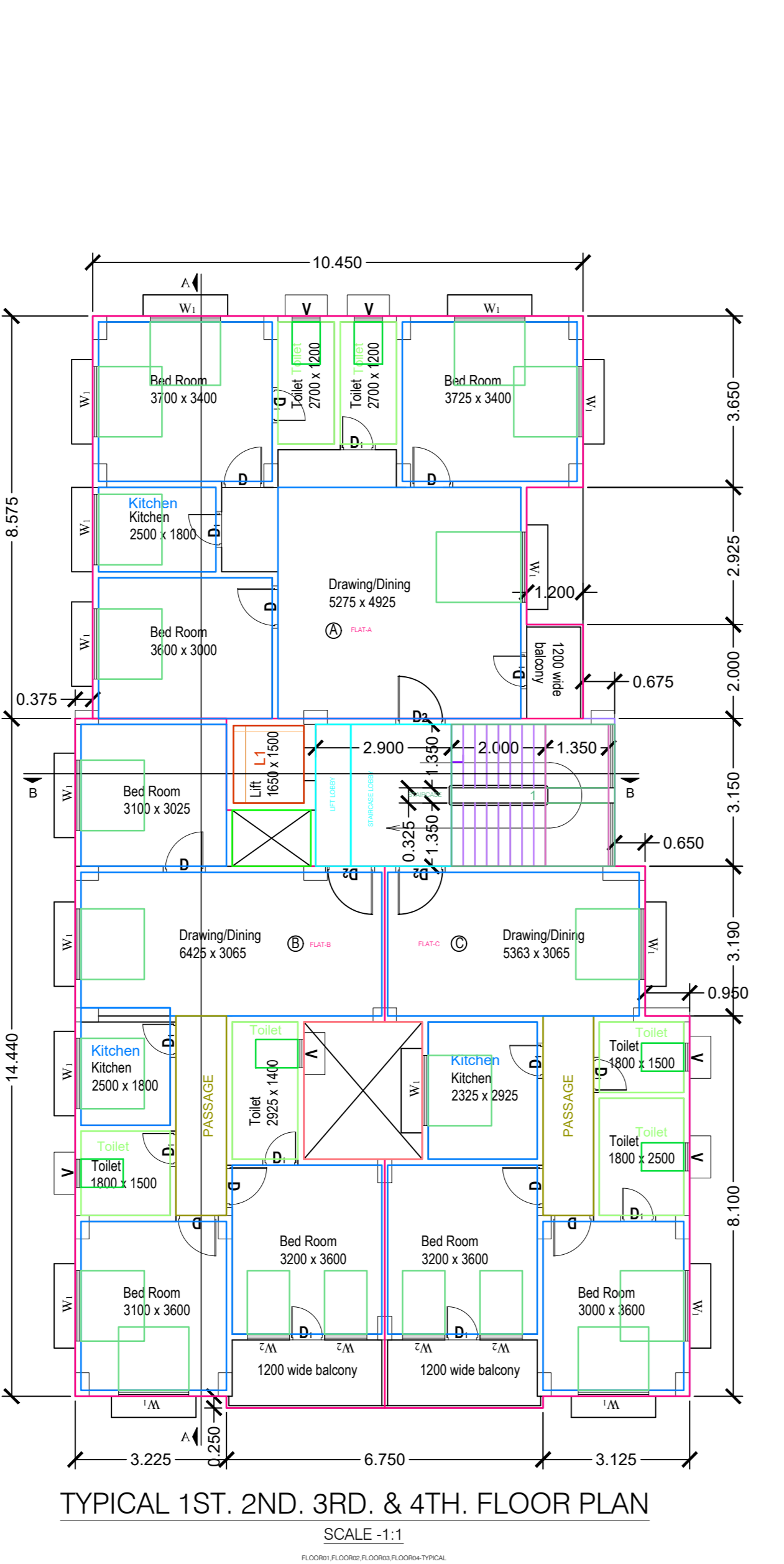
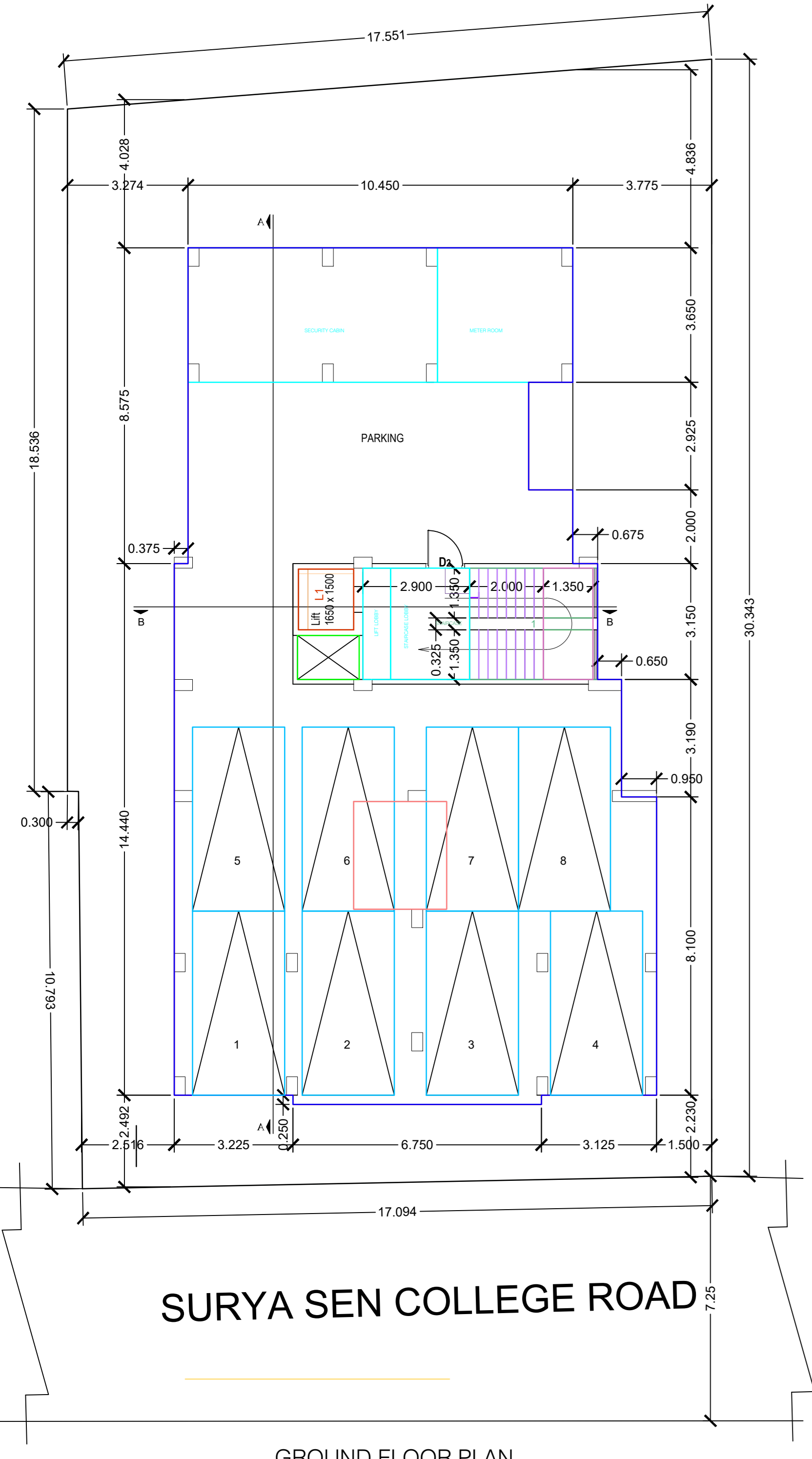
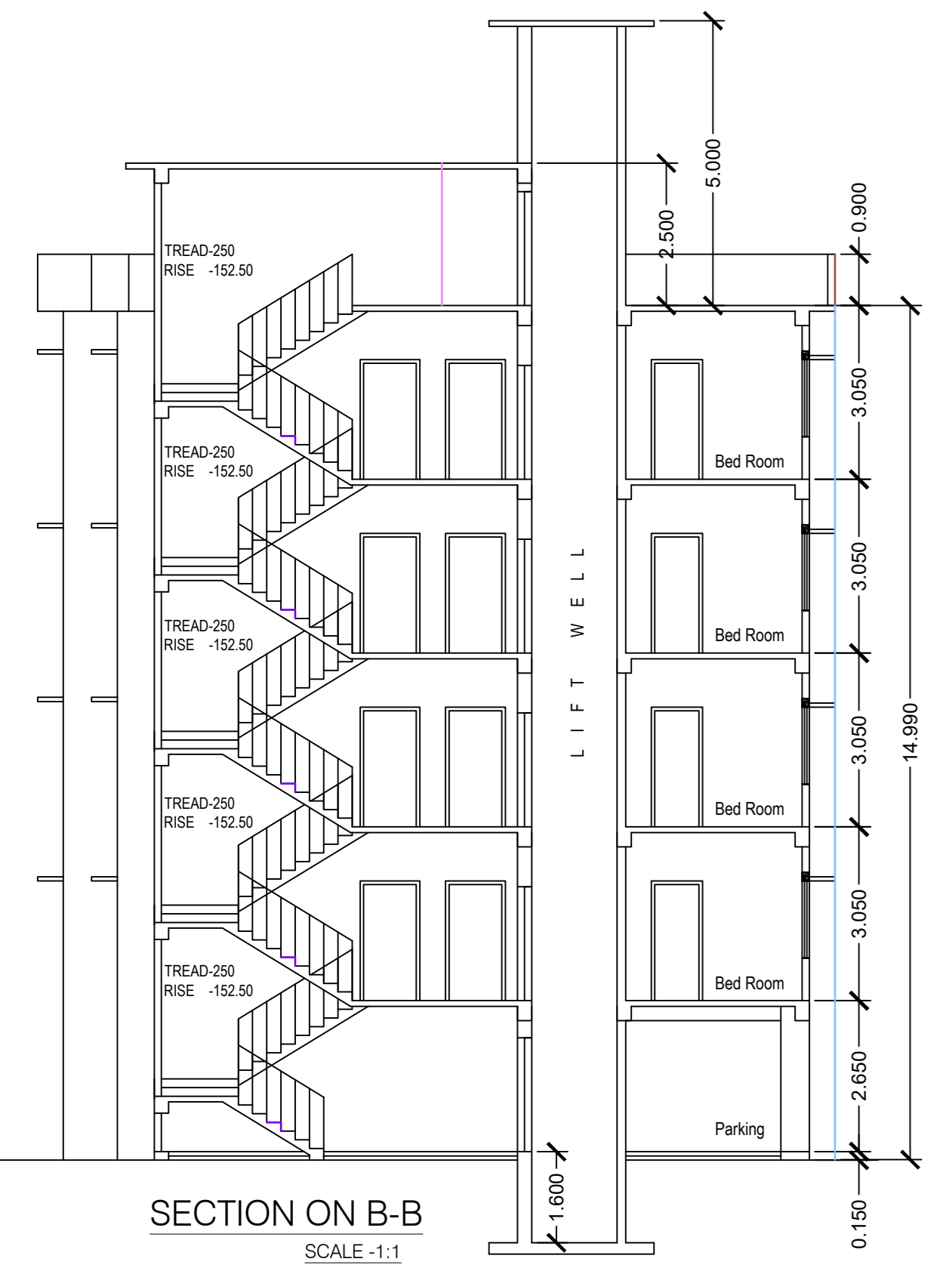

**SHEET**